

Relative Constructions in Maltese

Maris Camilleri

University of Surrey

Maltese has a number of formal types of relative constructions (RCs) related with different sorts of relational RCs, including restrictive RCs (RRCs), non-restrictive/appositive RCs (NRRCs/ARCs), and fused/free RCs (FRCs). Among the formal differences across Maltese RCs is the type of relativisation strategy they employ, such that for example, in the Standard variety, non-RRCs are restricted to complementiser-introducing strategies, unless preposition-fronting is involved, in which case a restricted set of *wh*-pronouns is allowed. FRCs, on the other hand, are introduced by a special set of *wh*-pronouns which narrowly overlaps with the set of *wh*-pronouns used in preposition-fronted RCs. Another formal difference which exists in Maltese RCs is the nature of the in-clause function, which could be either a GAP, or a *pro* with a resumptive status. The description of Maltese RCs is followed by a syntactic analysis whereby for each formal type of RC, constituent- and feature-structures are constructed within a Lexical Functional Grammar approach.

1. INTRODUCTION

This paper documents and introduces a description of Maltese relative constructions (hereafter referred to as RCs). Maltese is a mixed language (Aquilina 1959), belonging to the Semitic family. What descriptions are available for the language, which deal with the constructions under discussion here, namely Borg & Azzopardi-Alexander (1997), provide a very limited description of one type of RC. For this reason, this paper aims to contribute more to the description of these constructions in the language, whilst formalising this within an introductory analysis in Lexical Functional Grammar (LFG) (Dalrymple, 2001). The RCs in Maltese, which are essentially externally-headed and postnominal, as is the case with other head-adjunct constructions, will be described and analysed according to how they fare along two distinct parameters from the set of typological RC-related parameters posited in de Vries (2001). Section 2 looks at the relational-type parameter and discusses three types of RCs in the language, while in section 3, the focus will be on the relativisation strategy employed by these different types of RCs, which is then followed by a theoretical analysis within the LFG framework. Section 4 concludes the discussion.

2. RELATIONAL RCs IN MALTESE

In this section, three types of relational RCs shall be discussed for Maltese: Restrictive RCs (RRCs), Non-Restrictive/Appositive RCs (NRRCs/ARCs), and Fused/Free RCs (FRCs). While the focus on these three types does not entail that these are the only RCs available in the language, up to now these are the only ones which have been described and/or researched: Borg & Azzopardi-Alexander (1997) present a brief description of RRCs, Camilleri & Sadler (to appear) present a study on NRRCs/ARCs, while Camilleri (2010) provides a general discussion on all these three types of RCs. Each RC is here presented with a description of its idiosyncratic properties, and some theoretical considerations are presented that will affect the analysis in section (3).

2.1. Restrictive RCs

RRCs, by Murelli's (2008: 2) definition, function as attributes which qualify heads, restricting that same head's denotation whilst delimiting and narrowing down potential reference. In other words, RRCs modify their hosts (Fabb 1990: 57). An illustration of a regular RRC used in the Standard variety is given in (1).

- (1) *It-tifel* *li* *raj-t* *barra*
 DEF-boy that see-PERF.1.SG outside
 'The boy that I saw outside'

2.2. Non-Restrictive/Appositive RCs

In the literature, these RCs are referred to as *non-restrictive* or *appositive*, interchangeably, and are best understood when contrasted with RRCs. They are referred to as *non-restrictive* because while RRCs restrict reference, NRRCs do not. The term *appositive*, on the other hand, correlates with what Huddleston (2002: 1064) refers to as 'supplementary' relatives, which are used as a means by which a narrative may develop, while at the same time also providing more background information needed on the head within the discourse context. NRRCs/ARCs differ from RRCs in the following ways:

2.2.1. Prosody

NRRCs/ARCs, unlike RRCs, form a separate intonational unit, and are not prosodically integrated with their antecedents. In speech, this is conceived through a 'break' in the speech flow prosodically characterised by a small pause which separates the antecedent/head from the rest of the clause. Orthographically, this is shown through a (,), as in (2) below.

- (2) *It-tifel,* *li* *raj-t=u* *ilbieraħ*
 DEF-boy that see-PERF.1.SG=3.SG.M yesterday
 'The boy, who I saw yesterday'

2.2.2. Modification vs. Specification of information

As introduced in the beginning of this sub-section, while RRCs are used to help restrict reference, NRRCs/ARCs function as a means by which more information on the head is specified. As a result, a NRRC/ARC may never be used to act as an 'intersective modifier', since the head of this type of RC can only be interpreted in its 'totality' (Arnold, 2004). This in turn explains why (3) is an infelicitous construction. Since the ARC's head *il-kotba* 'DEF-book-PL' is interpreted as a whole, without any potential set interpretation, the additional statement which refers to *l-oħrajn* 'DEF-other.PL' is infelicitous.

- (3) *Il-kotba,* *li* *xtraj-t* *ilbieraħ,* *tajbin.* *#L-oħrajn*
 DEF-book.PL that buy-1.SG yesterday good.PL DEF-other.PL

mhux *hazin.*
 COP.3.SG.M.NEG bad.3.SG.M
 'The books, which I bought yesterday, are good. #The others, not quite'

As a consequence of the NRRC/ARC having a specificational function, instead of a restricting/modificational one, it may optionally be omitted. A RRC is always required whenever it occurs, as it allows access to the necessary reference. In relation to this

specificational vs. modificational function between RRCs and NRRCs/ARCs, as expected, there are several differences between the potential set of antecedents which these two types of RCs can take. The contrast in (4a-b) illustrates how a proper noun cannot head a RRC, as the ungrammaticality of (4a) shows, since the proper noun's 'reference is independently established' (Manninen 2002: 2), and hence does not need to be restricted in any way. By virtue of being endowed with its own reference, a proper noun, on the other hand, can head a NRRC/ARC. A similar observation can be shown in the contrast between (5a-b), where a non-clitic fully-fledged pronominal element can head a NRRC/ARC, but not a RRC. The examples in (6a-b) illustrate how since a temporal DP head does in itself have reference, this too cannot head a RRC.

- (4a) *Pawlu li j-oqghod hdej=na (RRC)
 Paul that 3sg-live near=1.PL
 Lit: 'Paul that lives near us'
- (b) Pawlu, li joqghod hdejna (NRRC/ARC)
- (5a) *Lilha li n-af=ha sew ... (RRC)
 Her that 1.SG-know=3.SG.F well ...
 Lit: 'Her that I know well ...'
- (b) Lilha, li nafha sew ... (NRRC/ARC)
- (6a) *Il-ġimgħa d-diehl-a li se t-kun vaganza (RRC)
 DEF-week DEF-entering-SG.F that FUT 3.SG.F-be holiday
 Lit: 'The next week that will be a holiday'
- b. Il-ġimgħa d-diehla, li se tkun vaganza (NRRC/ARC)

(7a-b) on the other hand illustrate the opposite effect with quantifier phrases (QPs). Since these are non-referential and non-specific, a NRRC/ARC cannot specify information on something which is not *anchored*, i.e. not having had its reference established as yet, unlike the case with RRCs, which can actually take such QPs as their heads.

- (7a) Hadd li n-af jien (RRC)
 No onethat 1.SG-know I
 'No one that I know'
- (b) *M'hemm hadd, li n-af jien (ARC)
 NEG.EXIST no one that 1.SG-know I
 Lit: 'There is no one, that I know'

Another interesting distinction between RRCs and NRRC/ARCs is their linear ordering with respect to each other. As shown in (8) below, a RRC always precedes an NRRC/ARC when this is present. Furthermore, while NRRCs/ARCs can be stacked, as illustrated in the three consecutive NRRCs/ARCs in (8), this is not possible with RRCs.

- (8) It-tifel [RRC]li n-af jien, [ARC]li soltu nara=h
 DEF-boy that 1.SG-know I that usually 1.SG-see=3.SG.M
 l-iskola, [ARC]li j-kun liebes dejjem pulit, [ARC]li
 DEF-school that 3-be dressing.SG.M always nice.SG.M that

n-af 'l omm=u]]]]
 1.SG-know ACC.mother=3.SG.M
 'The boy that I know, whom I usually see at school, who is always dressed nicely,
 whose mother I know'

2.2. Fused/Free RCs

The use of the term *fused* to refer to these RCs, which is the term which shall be adopted here following Huddleston (2002), is indicative of the function of the *wh*-pronouns such as *min* 'who' and *l min* 'whom' as used in (9). (Refer to section 3.3 for more detail on *wh*-pronouns in Maltese.)

(9a) *Min j-orqod ma j-aqbad=x* (Borg & Azzopardi-Alexander 1997:37)
 Who 3-sleep NEG 3-catch=NEG

ħut
 fish
 'Whoever sleeps does not catch fish' (Maltese Proverb)

(b) *Kellim-t l min raj-t*
 speak.PERF-1.SG ACC.who see.PERF-1.SG
 'I spoke to whomever I saw'

Using the terms *fused/free* RCs, rather than the other term used to refer to these constructions in the literature – *headless* constructions, which is also the term used by Borg & Azzopardi-Alexander (1997) when describing (9a) – is rooted in a controversial debate which seeks to see what the best analysis for constructions such as (9) should be. Pretheoretically, using the term *headless* to refer to these constructions is not justified, particularly when equating the constructions in (9), with (10). (10) exemplifies what one may want to treat as a *true* instance of a headless construction, where it is clear that no head precedes the element *li* which has so far, in the data in (1-8), followed the head and introduced the RC. The construction in (10) appears to have *no overt* head, and is hence *really* headless.

(10) [Li qed t-ghid=l=i], ga n-af=u
 that PROG 2.SG-say=DAT=1.SG already 1SG-know=3.SG.M
 Lit: '(that) that you are saying, I know-IT already'
 'I already know (about that) that you are saying'

Theoretically, the proponents of the *headless*-RC treatment of instances like (9) account for these constructions through the complementiser approach, where FRCs are taken to be CPs that act as modifiers of null/empty heads (Grosu & Landman 1998: 127). The alternative account of FRCs is the one which is followed here, where the *wh*-pronoun is taken to be the head of the whole RC and is thus referred to as the *headed*-analysis (Citko, 2002) (Bresnan & Grimshaw, 1978). Taking the *wh*-element as the head implies that the whole FRC is an NP/DP, and that the *wh*-pronoun carries two θ -roles or grammatical functions (GFs); the GF of the matrix clause's predicate, and its within-clause function subcategorised for by the embedded clause's predicate (Ott, 2011). Evidence for this approach comes from the same FRCs' distribution, where in Maltese such constructions can occur in all main clause nominal GF positions available for the languages, which range from SUBJ position (9a) and OBJ position (9b), to adnominal POSS GF as in (11), as well as others.

- (11) Oht min ġab dal-ktieb, t-af=ni
 Sister who get.PERF.3.SG.M DEM.DEF-book 3.SG.F-knows.1.SG
 ‘The sister of whoever got this book, knows me’

Another piece of data supporting the headed-account vs. the complementiser one comes from the fact that the latter account will not be able to explain why it is the case that a FRC can be modified with a RRC, just like any other NP, as shown in (12).

- (12) Kulma qlajt għall-berdej [RRC]li
 All.what receive.PERF-1.SG for.DEF-birthday that
 m’ghogob=ni=x]
 NEG.3.SG.M.like.1.SG.NEG
 ‘Whatever (all that) I received for my birthday which I didn’t like’

Moreover, what (13) instantiates, although seemingly trivial perhaps, is the fact that when the FRC in (13a) is substituted with a RRC equivalent in (13b), it is both the head *dak* ‘DEM.SG.M’ and the RRC together that substitute the FRC, which in turn does not render the complementiser analysis plausible, since, if the FRC were truly a CP, the substitution would not have involved the RRC’s head.

- (13a) T-af li [FRC]qal=li (Borg & Azzopardi-Alexander 1997:37)
 2.SG-know that what.tell.PERF.3.SG.M=DAT.1.SG

koll-u nsej-t=u?
 all-SG.M forget.PERF-1.SG=3.SG.M
 ‘Do you know that I have forgotten whatever he said?’

- (b) T-af li [dak [RRC]li qal=li]
 2.SG-know that DEM.SG.M that tell.PERF.3.SG.M=DAT.1.SG

koll-u nsej-t=u?
 all-SG.M forget.PERF-1.SG=3.SG.M
 ‘Do you know that I have forgotten that which he told me?’

3. RELATIVISATION STRATEGIES

The relativisation strategy parameter looks at ways in which RCs are introduced, as well as what RC-internal strategies may be employed. Section 3.1 looks at the different complementiser strategies used in the language. Section 3.2, on the other hand, discusses the RC-internal GAP and resumptive pronoun (RP) strategy in Maltese, while the final subsection discusses the use of *wh*-pronouns. An LFG analysis of the data will follow for each section.

3.1. *Li* and partitive *milli*

Grouping RRCs and NRRCs/ARCs together, one of the possible relativisation strategies is that which equates to *that*-relatives in English (for a justification of this refer to Camilleri (2010), since space limitations restrict any further illustration here). Maltese makes use of the complementiser *li* ‘that’, which has developed from the *wh*-pronominal form *allađi* ‘who.3.SG.M’ and the rest of the paradigm in Standard Arabic. The language, however, also uses a variant form; *milli* ‘from which’, which is here treated as a *partitive complementiser*, which comes about through the fusion of *minn* ‘from’, out of which the partitive meaning is

essentially projected, and the complementiser *li*. What follows is an LFG analysis of the *li*-introduced RRC in (1), which includes the constituent-structure (*c*-structure) in (14a) and the feature-structure (*f*-structure) in (14b). A NRRC/ARC LFG analysis is given in (17), which is illustrated with an example of a *milli*-introduced RC.

It-tifel li rajt barra

(14a) *Annotated c-structure*

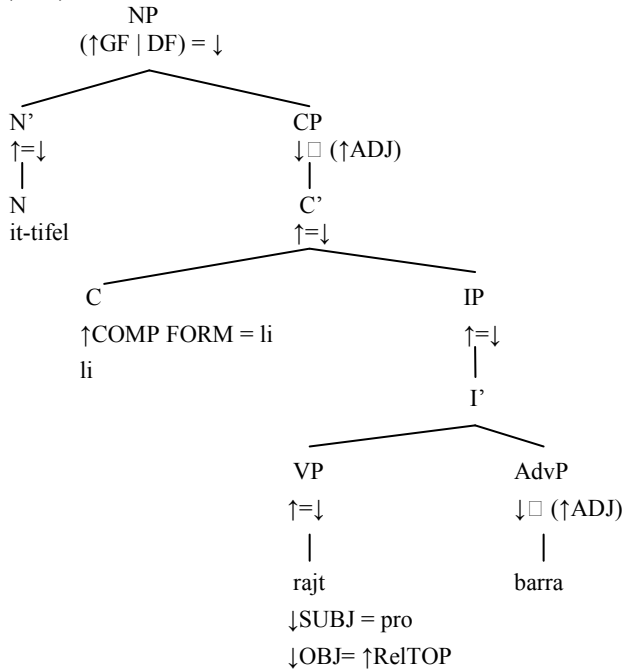

(b) *li-introduced RRC f-structure*

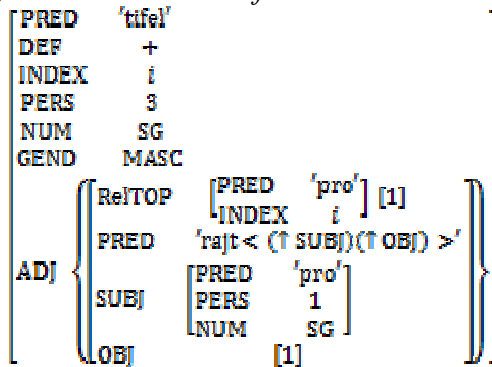

From these structures one observes that LFG treats RCs as ADJuncts, and that the *f*-structure for RCs, as well as other unbounded-dependency constructions, is characterised by dependencies. Initially there is the dependency mentioned in Zaenen (1983: 486), which is anaphoric in nature and relates the RelTOP *pro* with the head of the RC via coindexation, which is captured by the index matching between the head and the RelTOP, in (14b). The other dependencies which may be present are more theoretically-driven. The dependency that is relevant to *li*-/*milli*-introduced RRCs and NRRCs/ARCs is that which exists between the RelTOP DF within the ADJ and the GF it occupies within the ADJ's *f*-structure, represented through [1], in (14b). This dependency comes about as a result of the Extended Coherence Condition (ECC), which states that:

- (15) “FOCUS and TOPIC [i.e. discourse functions (DFs)] must be linked to the semantic argument structure of the sentence in which they occur, either by functionally or by anaphorically binding an argument.” (Bresnan & Mchombo 1987: 746).

The ECC thus explains why dependencies need to come about, and hence results in the need for the RelTOP, which is a DF, to be functionally identical with a GF, which happens to be the OBJ in (14). A further intricacy which may also need to be understood is that this RC-analysis is what Falk (2010) calls *mediated*: that is, in the *f*-structure in (14b), it is assumed that in the case of non-*wh*-pronoun introduced RCs what exists is actually a non-overt *wh*-fronted pronoun. This in turn leads to another issue. How is a null *pro* RelTOP accounted for, if, as shown in the *c*-structure in (14a), there is no empty category being postulated? To account for both these facts, i.e. the absence of null elements in the *c*-structure, and the requirement to have a RelTOP in these constructions within the *f*-structure, is to use the \square device as proposed in Dalrymple, Dyvik & King (2004). Using \square does not imply ‘an empty category’, and thus has no effect on the *c*-structure, but rather it is stated as part of the phrase structure rules, and stipulates a PRED ‘pro’ value to a RelTOP DF. The DF is thus not related to any lexical entry and has no semantic content, and is only present when the RC is introduced by a complementiser strategy. The CP rule for complementiser-introduced RCs would look like (16):

- (16) CP \rightarrow \square C'
 \uparrow RelTOP = ‘pro’ $\uparrow=\downarrow$
 \uparrow RelTOP INDEX = (\uparrow GF| \uparrow DF) INDEX

What follows is the *c*-structure for a *milli*-introduced NRRC/ARC.¹

- (17a) Il-pasti, milli sajjar-t=l=ek jien
 DEF-buns from.that cook.CAUS-1.SG=DAT=2.SG I
 ‘The buns, from (the ones) I cooked (for you)’

(b) Annotated *c*-structure

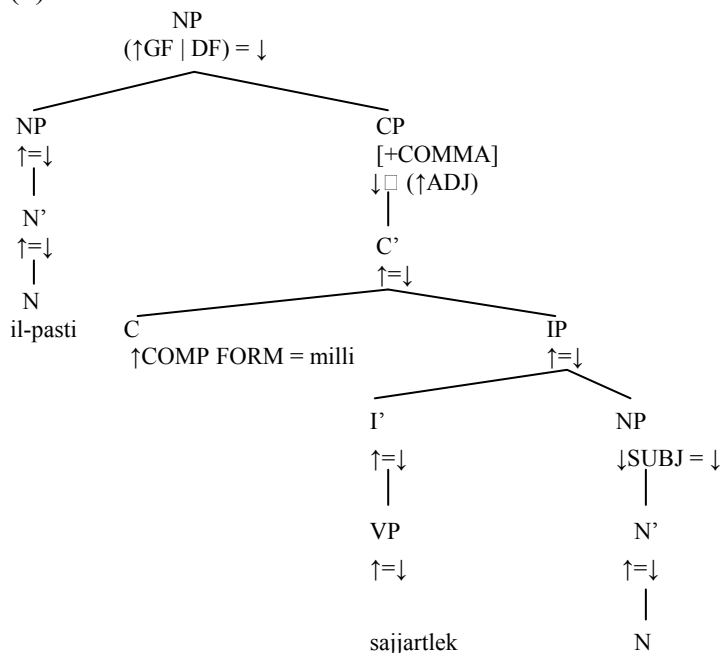

¹ Due to space restrictions, the *f*-structure is not given: however, this analysis of NRRCs/ARCs parallels that of RRCs.

↓OBJ= ↑RelTOP jien
 ↓DAT OBJ= pro

There exists a debate in the literature about how to best present the structure of NRRCs/ARCs, i.e. whether they should be treated as some kind of separate constituents, or as instances of embedded, syntactically-integrated constructions. Under the former approach, NRRCs/ARCs are treated as independent sentences having a completely distinct syntax from RRCs. On the other hand, evidence favouring a complementation or syntactically-integrated approach for these constructions in Maltese comes from word order cues. While an enclitic pronoun can be the final element in a main clause, this is not the case in RC contexts, which thus implies that RRCs and NRRCs/ARCs should both be considered to have the same embedded structure. When one looks at the *c*-structure in (17b), one notes that in fact, the CP is essentially the same as that suggested for RRCs, except that in NRRCs/ARCs this constituent is attached to an NP rather than to an N', following Arnold & Borsley (2008) and Arnold & Sadler (2010). What this shows is that the CP hosting this RC does not function as a modifier, unlike the case with RRCs, whose modifier interpretation comes by virtue of being in an ADJ position in relation to the NP head. The [+COMMA] feature added on the CP intends, on the other hand, to show that there exists a mapping between the *c*-structure and the prosodic structure, which would account for the comma interpretation of NRRCs/ARCs.

3.2. The GAP vs. Resumptive Strategy

(14b) above illustrated an instance of functional-identity between the RelTOP and the OBJ GF where the [1] index in the *f*-structure represented the fact that the dependency involved was a re-entrancy of the RelTOP in the OBJ GF position, since there was no PREDicate value related with the OBJ attribute. The internal-relativisation strategy employed in (14) (and (17)) is referred to as the GAP strategy. In a RP strategy, on the other hand, which in Maltese interacts with the complementiser strategy, an ordinary pronoun is present in an argument position and anaphorically-binds the RelTOP to it, in accordance with the ECC. For this reason, Asudeh (2004) calls constructions involving RPs as *binder-resumptive*. By employing a RP strategy, as in (18) below, the OBJ of *naf* '1.SG-know' is a pronominal enclitic. This implies that the ADJ OBJ has its own PRED value, as illustrated in (18b).

(18a) Tifel li n-af=u sew
 DEF-boy that 1.SG-know=3.SG.M well
 'A boy that I know very well'

(b) *f*-structure involving a RP Strategy in a li-introduced RRC

PRED	'tifel'		
DEF	-		
INDEX	i		
PERS	3		
NUM	SG		
ADJ	{	RelTOP	[
			PRED
			INDEX
			'pro'
			i
]σ
			PRED
			'naf < (↑ SUBJ)(↑ OBJ) >'
			SUBJ
			PRED
			'pro'
			PERS
			1
			NUM
			SG
			OBJ
			PRED
			'pro'
			PERS
			3
			NUM
			SG
			GEND
			MASC
]σ

As (18b) exemplifies, since a RP is present, the RelTOP-ADJ OBJ dependency cannot involve a re-entrancy. This is constrained from taking place by the *f*-structure's Uniqueness

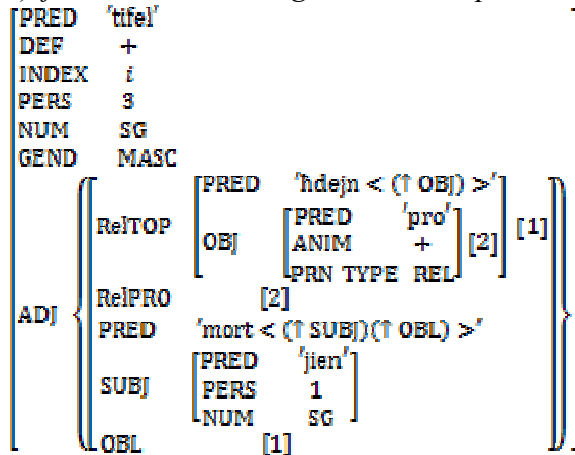
(20) *f*-structure involving an overt *wh*-pronoun in a preposition-fronted RRC3.3.2. *Wh*-pronouns and FRCs

The use of the *wh*-pronoun in FRCs, as discussed in section 2.3, differs from the cases discussed in section 3.3.1. To start with, the inventory of *wh*-pronouns used in FRCs is larger than, and distinct from, those used in non-FRCs, although there is a marginal overlap.³ However, apart from inventory distinctions, the very function of the *wh*-pronouns differs between the two constructions. While the *wh*-pronouns in (19) are relative pronouns, the ones found in FRCs are not (Kluck, 2007). This explains why in the *f*-structure analysis of (9b) (in section 2.3), given in (24) below, there is no RelTOP–RelPRO dependency. Moreover, as also mentioned in section 2.3, the *wh*-pronoun bears a GF assigned by the main clause PRED, apart from having its own GF in the ADJ *f*-structure. The assumption held here is that FRCs include a modifier clause, and hence involve an ADJ function. This finds proof in the fact that such constructions render themselves as modifiers of their *wh*-pronominal heads. Furthermore, following the approach upheld here, i.e. that the *wh*-pronoun in these constructions is a GF, it is required that the phrase structure rule has the necessary annotation stipulating the obligatory presence of a RC (Rooryck 1994), since *wh*-pronouns from the set of pronouns restricted to FRCs can never appear without being in juxtaposition with their modifying RC in Maltese. This stipulation is possible if the set of *wh*-pronouns used in FRCs is distinguished from those used in non-FRC contexts, i.e. by giving the former a PRN TYPE FREE feature-value in their lexical entry, which will distinguish them from the PRN TYPE REL set used in non-FRCs. This will also be a felicitous way with which to account for the fact that in Maltese, these two sets of pronouns are broadly characterised by distinct forms.

Following this treatment of *wh*-pronouns in FRCs, the next question to consider concerns how to account for the fact that such *wh*-pronouns are also functionally identical with a GF within the ADJ, if they are not treated as relative pronouns, but rather as regular GFs subcategorised for by the matrix PRED. If a sort of dependency such that on the DP in the phrase structure rule the annotation in (21) is formulated, which states that the constituent's GF or DF is functionally identical to a GF which is part of the ADJ modifying the same DP, a dependency which fulfils the ECC *can* take place. However, this dependency will result in a re-entrancy in the ADJ GF position, which will involve the whole matrix GF/DF's *f*-structure, including the same ADJ inside it, which is a bad construction that can in principle keep taking place endlessly. Before actually proceeding to the LFG analysis proposed here, a brief overview of the distinct LFG analyses in the literature is given.

$$(21) \quad \uparrow\text{GF}|\uparrow\text{DF} = (\downarrow\text{GF}e(\uparrow\text{ADJ}))$$

³ Space reasons restrict a thorough description, but refer to Camilleri (2010).

The LFG analysis proposed here for Maltese FRCs takes the *wh*-pronoun as a *free* type which heads an FRC.⁴ Following the discussion in section 3.3.2, a RelTOP analysis is still required in this account, and cannot be done without, unless a RelMOD as in Dalrymple & Kaplan (1997) is retained, which on the other hand has the misfortune of hindering a unified *f*-structure analysis of RCs, whilst treating the modifying clause in the FRC as something completely distinct from RRCs. The proposed *headed* analysis of FRCs is displayed in (25), which is part of what the phrase structure rule for a construction such as (9b) would include. Under the DP node in the *c*-structure, the *free wh*-pronoun is associated with a GF, which, just as in other RC structures, is also in a dependency with the RelTOP. One notes that the pronominal element's requirement to be related with the RelTOP fulfils the stipulation which *free wh*-pronouns impose, i.e. to be obligatory followed by a modifying RC, in Maltese. The RelTOP analysis proposed here under the *headed* FRC account should be understood to be equivalent to the analysis assumed for *li/milli*-introduced RCs, where a null-pronominal element fulfils this function. The only essential difference between FRCs and RRCs lies in the *c*-structure, where in the former there will be no C-node heading the CP-modifying constituent. Thus, the co-indexing dependency taking place in the information-structure (as the *i* notation represents), is one which links the *free wh*-pronoun with the covert 'pro': the RelTOP function. From there, the RelTOP-GF dependency required by the ECC follows as usual, which in turn explains how the *wh*-pronoun takes the role of two GFs in these constructions.

$$\begin{array}{lcl}
 (24) \quad VP & \rightarrow & V' \quad DP \\
 & & \uparrow = \downarrow \\
 & & (\uparrow \text{PRED}) = \text{'pro'} \\
 & & (\uparrow \text{PRN TYPE}) = \text{FREE} \\
 & & (\uparrow \text{OBJ}) = \downarrow \\
 & & (\uparrow \text{OBJ})_i = (\uparrow \text{RelTOP} \in (\downarrow \text{ADJ}))_i
 \end{array}$$

(25) illustrates the *f*-structure analysis of a FRC in Maltese assuming a *headed* approach.

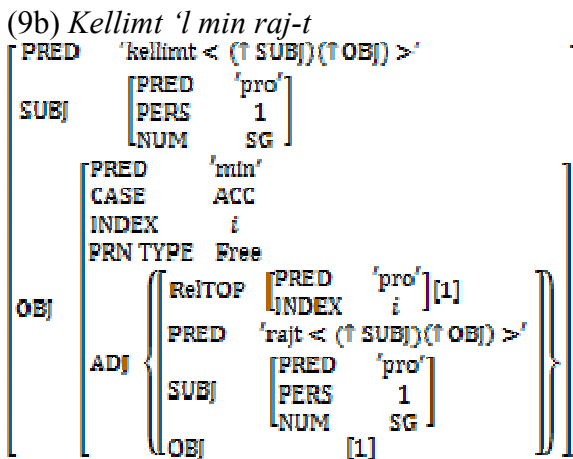

4. CONCLUSION

This paper provided a brief overview of three RCs found in Maltese; restrictive, non-restrictive/appositive, and fused/free RCs. Their description was complemented with an analysis formulated within Lexical Functional Grammar. The two relativisation strategies

⁴ Note that the use of the term *relative constructions* vs. the more common term *relative clauses* finds a justification at exactly this point, in that under a headed analysis of fused constructions, these cannot be treated as *clauses*, since they are taken to be NPs. The use of the term *constructions* thus accounts for all FRCs and non-FRCs, without imposing any analytical bias.

employed in Maltese RCs were discussed, and it was shown that while the complementiser strategy is related to both the GAP and resumptive pronoun strategies, *wh*-introduced RCs as found in the Standard variety of the language, restricted as they are to preposition-fronted contexts, are only related to the in-clause GAP strategy. In the final section, an LFG analysis for fused/free RCs viewed from a headed approach was proposed, which unlike previous analyses does not take the *wh*-pronoun to be a relative pronoun within the RC. This paper has aimed to provide a stimulus for further research, and in particular for more descriptive work to be undertaken in Maltese, to see what other RCs exist there, as well as other theoretically-driven research which could expand and advance the proposals above.

REFERENCES

- Aquilina, Joseph (1959) *The Structure of Maltese: A study in mixed grammar and vocabulary*. Msida: Royal University of Malta.
- Arnold, Douglas (2004) Non-Restrictive relative clauses in construction based HPSG. *Proceedings of the HPSG04 Conference*.
- Arnold, Douglas and Robert Borsley (2008) Non-restrictive relative clauses, ellipsis and anaphora. *Proceedings of the HPSG08 Conference*.
- Arnold, Douglas and Louisa Sadler (2010) Pottsian LFG. *Proceedings of the LFG10 Conference*.
- Asudeh, Ash (2004) Resumption as Resource Management. Ph.D. Dissertation. Stanford University: CA.
- Borg, Albert and Marie Azzopardi-Alexander (1997) *Maltese*. NY: Routledge.
- Bresnan, Joan and Joan Grimshaw (1978) The syntax of free relatives in English. *Linguistic Inquiry* 9.3:331-191.
- Bresnan, Joan and Sam Mchombo (1987) Topic, pronoun, and agreement in Chicheŵa. *Language*, 63: 741-782.
- Camilleri, Maris (2010) *On Relative Constructions in Maltese*. MRes Dissertation. University of Essex.
- Camilleri, Maris and Louisa Sadler (to appear) An LFG approach to non-restrictive relative clauses in Maltese. *Proceedings of the ALS 2010 Conference*.
- Chatsiou, Aikaterini (2010) *A Lexical Functional Grammar analysis of Modern Greek Non-Restrictive Relative Clauses*. Ph.D Dissertation. University of Essex.
- Citko, Barbara (2002) (Anti)reconstruction Effects in Free Relatives: A new argument against the COMP account. *Linguistic Inquiry* 33: 507-511.
- Dalrymple, Mary (2001) *Lexical Functional Grammar. Syntax and Semantics, 34*, New York: Academic Press.
- Dalrymple, Mary, Helge Dyvik and Tracy Holloway King (2004) Copular Complements: Closed or Open? *Proceedings of the LFG04 Conference*.
- Dalrymple, Mary and Ronald Kaplan (1997) A set-based approach to feature-resolution. *Proceedings of the LFG97 Conference*.
- de Vries, Mark (2001) Patterns of Relative Clauses. *Linguistics in the Netherlands*, 1-13.
- Fabb, Nigel (1990) The difference between English restrictive and non-restrictive relative clauses. *Journal of Linguistics*, 26: 57-77.
- Falk, Yehuda (2010) An unmediated analysis of relative clauses. *Proceedings of the LFG10 Conference*.
- Grosu, Alexander and Fred Landman (1998) Strange Relatives of the Third Kind. *Natural Language Semantics*, 6: 125-160.
- Huddleston, Rodney (2002) Content clauses and reported speech. In R. Huddleston, and G. K. Pullum. *The Cambridge Grammar of the English Language* (pp. 947-1030). Cambridge: CUP.
- Kluck, Marlies (2007) Problems in Unifying Free Relatives. Retrieved from: <http://www.let.rug.nl/kluck/TABU2007.pdf> (16 July 2010).
- Larson, Richard (1988) On the Double Object Construction. *Linguistic Inquiry*, 19.3: 335-391.
- Manninen, Satu (2002) *Extraposition and restrictive relative clauses*. Ms. Lund University.

- Murelli, Adriano (2008) Relative constructions in European Languages: A closer look at non-standard varieties. *MEL-Kompaktvorlesung*, 1-14.
- Ott, Dennis (2011) A note on free relative clauses in the theory of phases. *Linguistic Inquiry*, 42.1: 183-192.
- Rooryck, Johan (1994) Generalized transformations and the WH-Cycle: Free relatives and bare Wh-CPs. *GAGL*, 37: 195-208.
- Zaenen, Annie (1983) On Syntactic Binding. *Linguistic Inquiry*, 14: 469-504.